

WIRING DIAGRAM C-5010T ECO BC 400V.

OPERATION 1

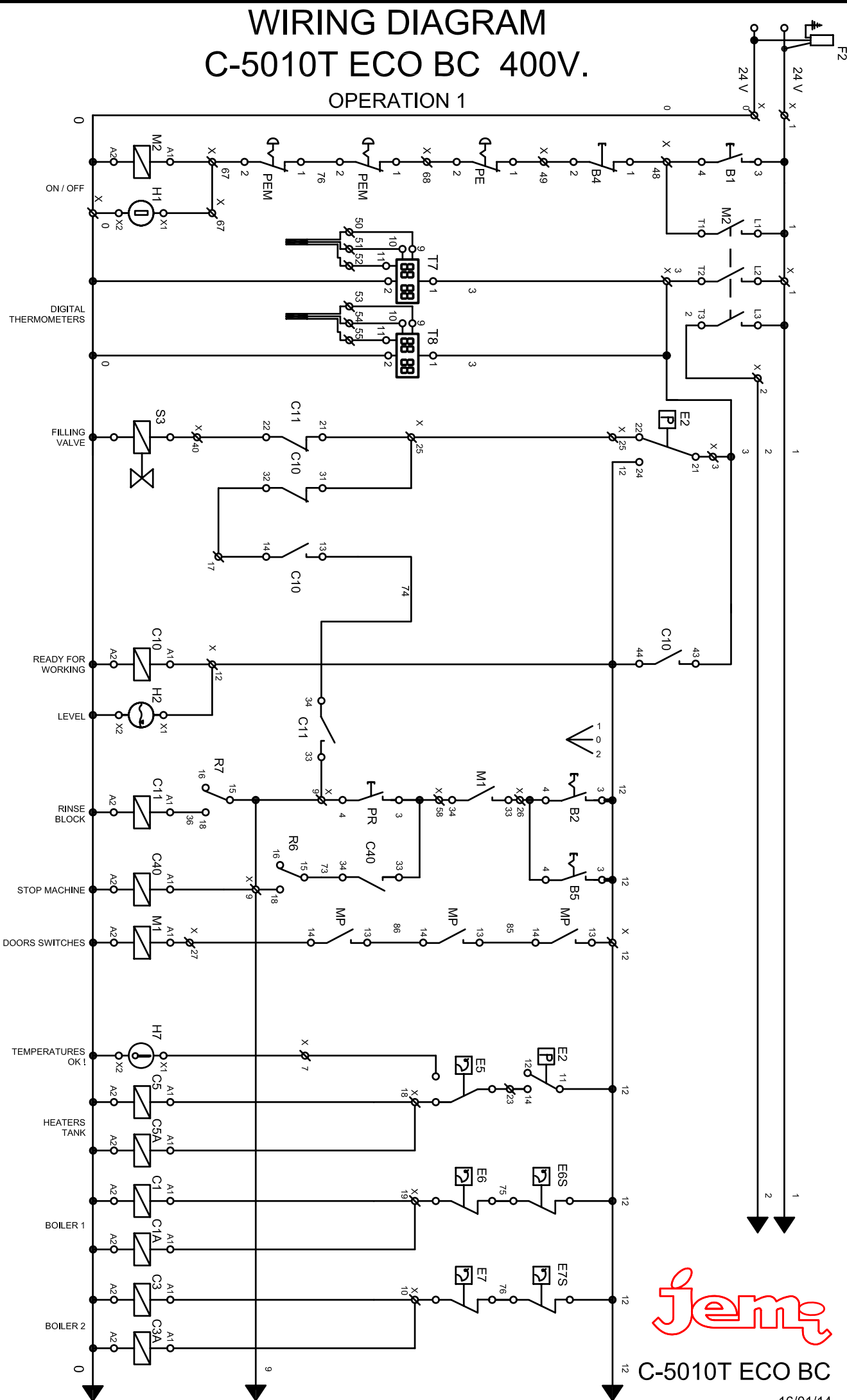

C-5010T ECO BC

WIRING DIAGRAM

C-5010T ECO BC 400V.

OPERATION 2

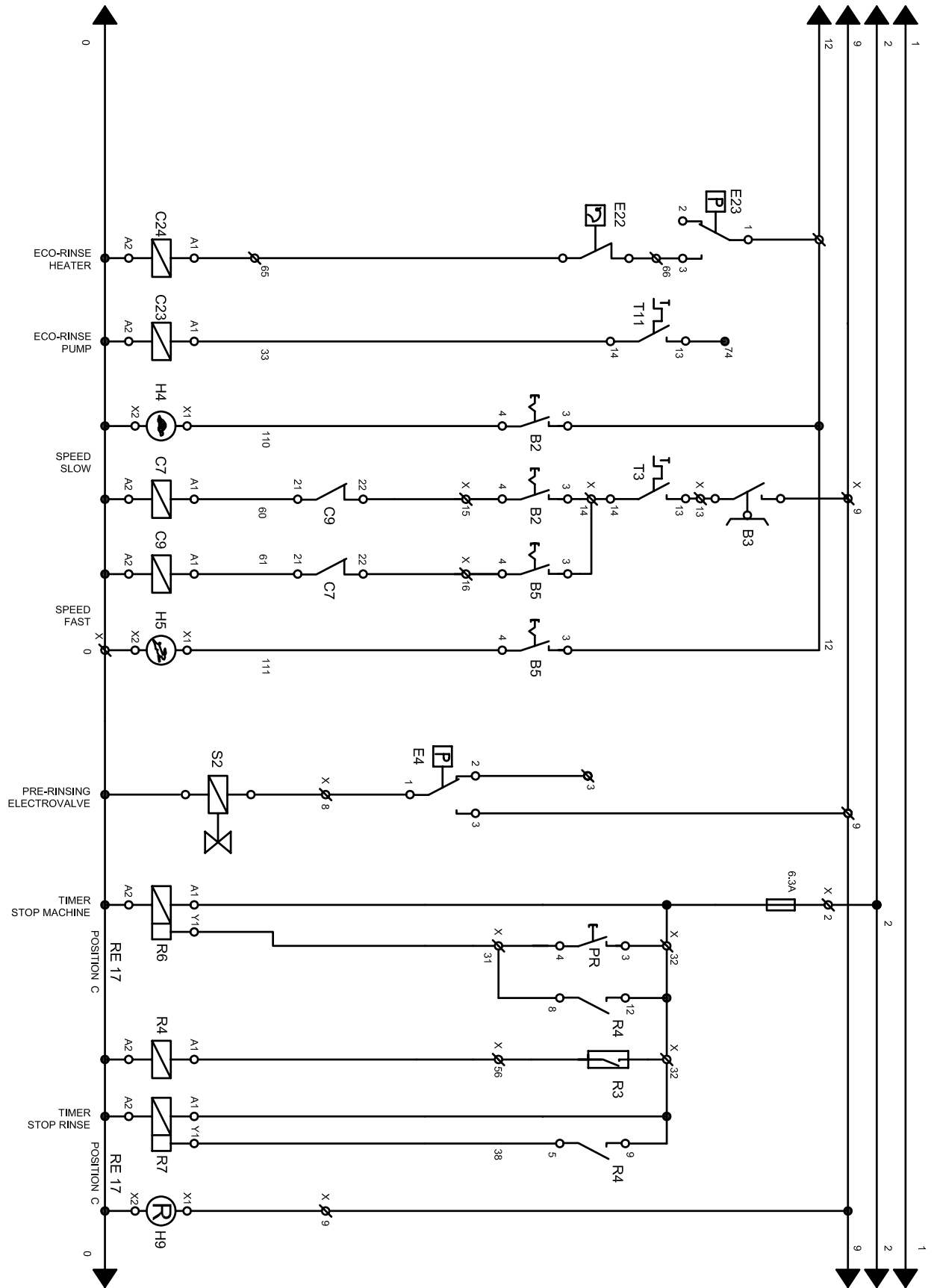

C-5010T ECO BC

WIRING DIAGRAM C-5010T ECO BC 400V.

OPERATION 3

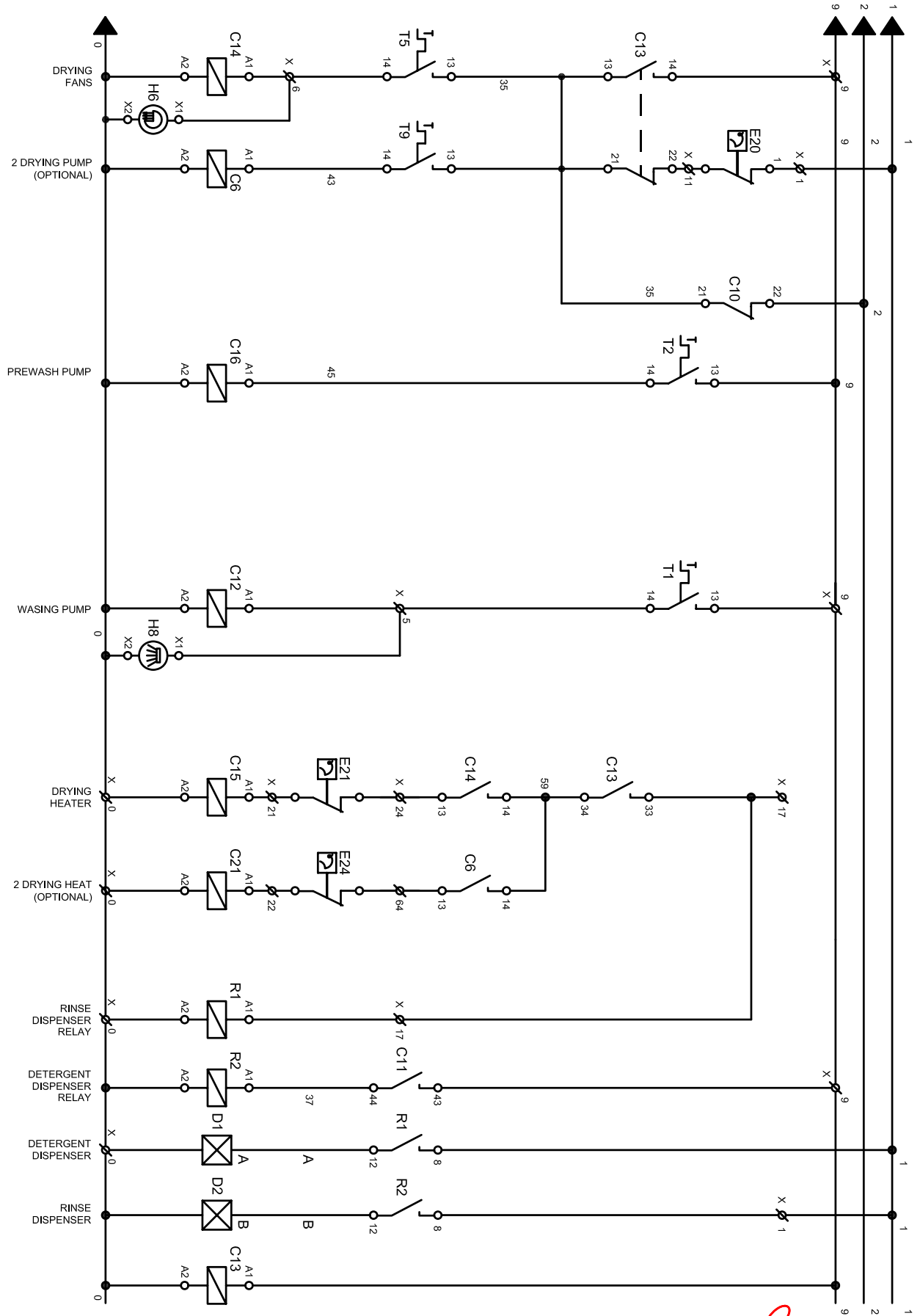

C-5010T ECO BC

WIRING DIAGRAM C-5010T ECO BC 400V.

OPERATION 4

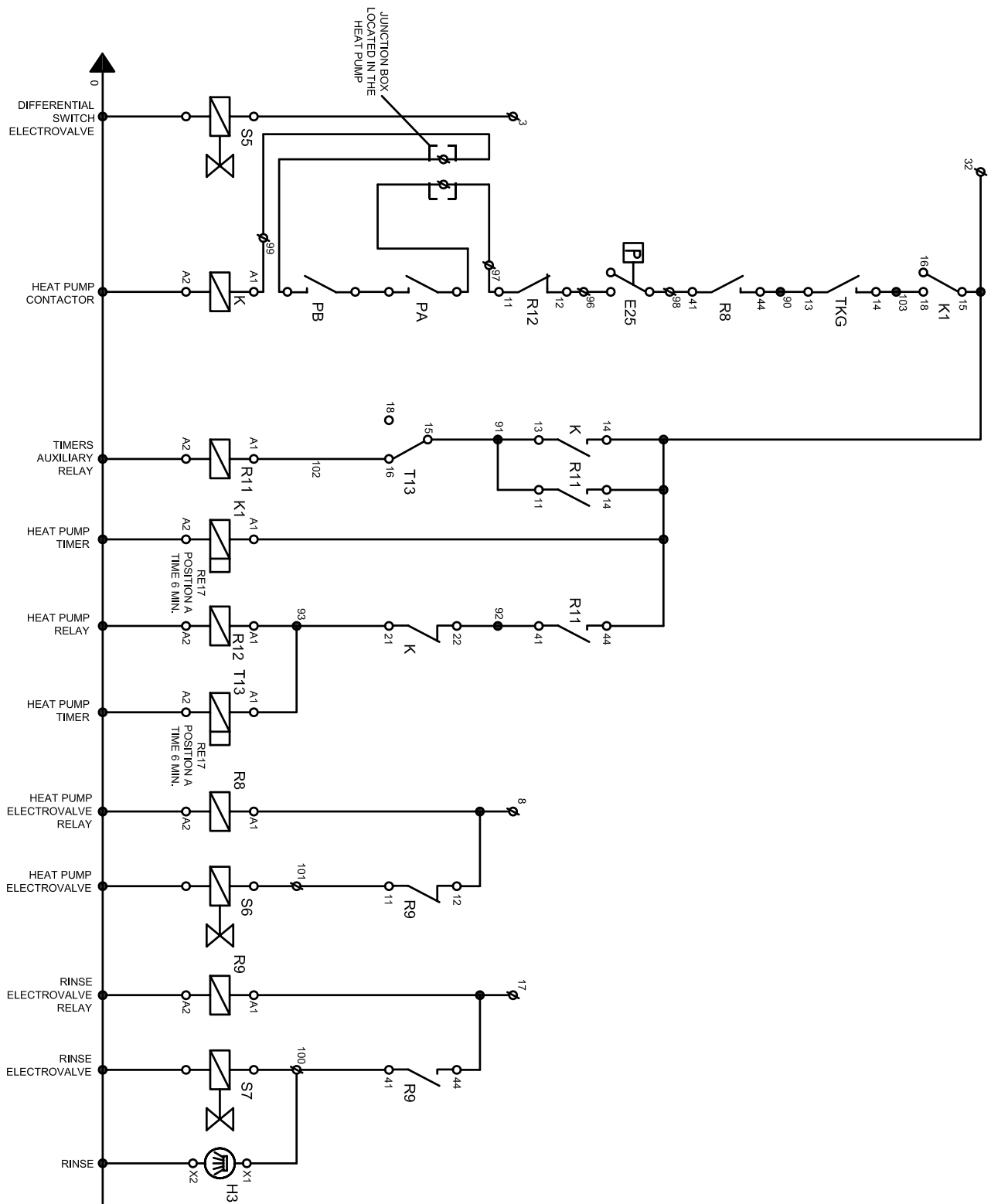

C-5010T ECO BC

WIRING DIAGRAM

C-5010T ECO BC 400V.

MOTORS PUMPS

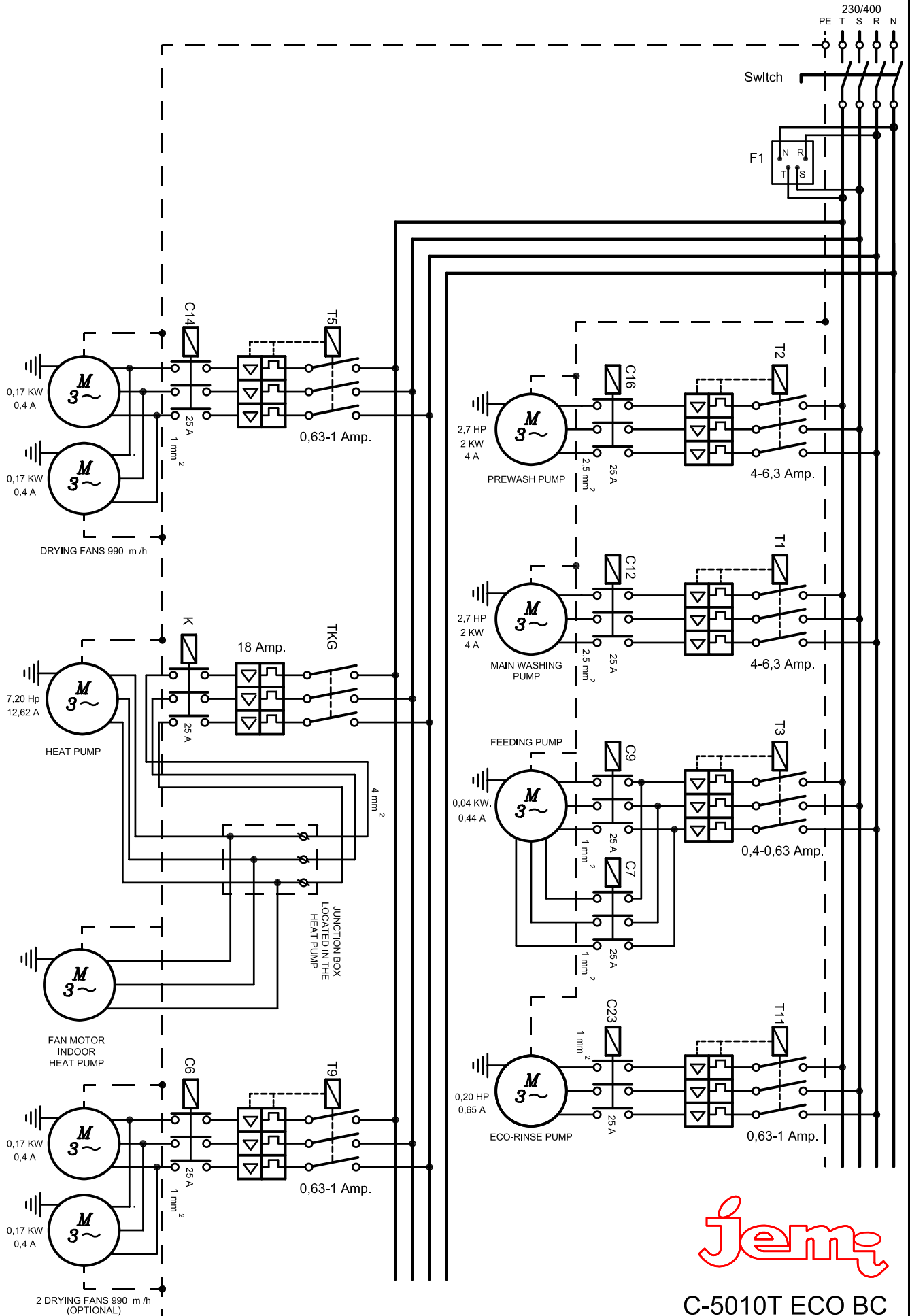

C-5010T ECO BC

EDITION 26610/094

WIRING DIAGRAM

C-5010T ECO BC 400V.

HEATER ELEMENTS

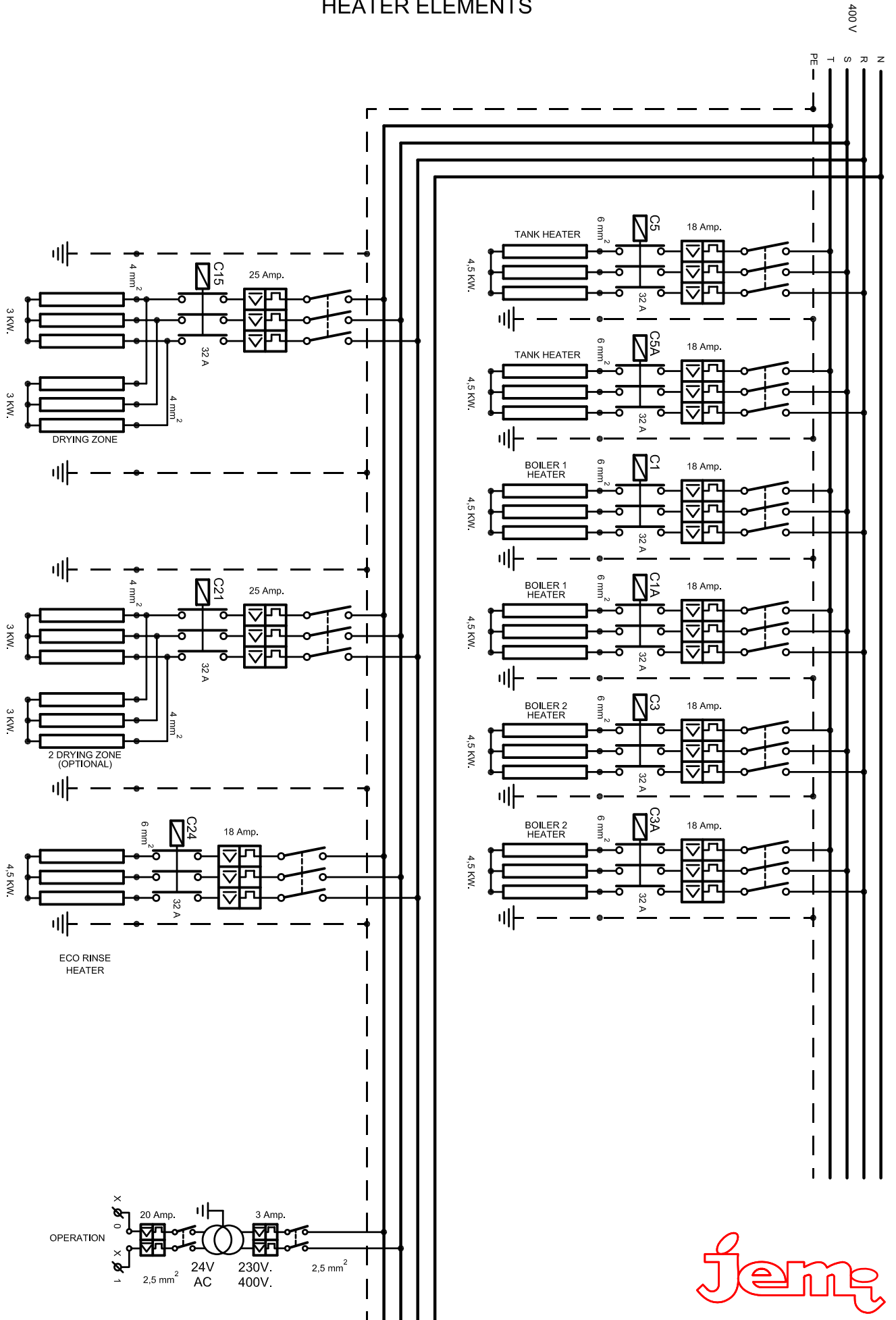

C-5010T ECO BC

ELECTRIC DIAGRAM INDEX

MOD: C-5010T ECO BC

H1	ON/OFF INDICATOR LIGHT
H2	LEVEL INDICATOR LIGHT
H3	RINSING INDICATOR LIGHT
H4	SLOW SPEED INDICATOR LIGHT
H5	FAST SPEED INDICATOR LIGHT
H6	AIR DRYING INDICATOR LIGHT
H7	CORRECT TEMPERATURES INDICATOR LIGHT
H8	WASHING INDICATOR LIGHT
H9	REARMEMENT INDICATOR LIGHT
T1	MAIN WASHING PUMP MOTOR GUARD C12
T2	PREWASHING PUMP MOTOR GUARD C16
T3	FEEDING MOTOR MOTOR GUARD C7, C9
T5	DRYING MOTOR MOTOR GUARD
T7	WASH TANK DIGITAL THERMOMETER
T8	RINSE DIGITAL THERMOMETER
T9	2 DRYING MOTOR GUARD (OPTIONAL)
T11	ECO RINSE PUMP MOTOR GUARD
T13	HEAT PUMP TIMER
C1	BOILER 1 HEATER CONTACTOR
C1A	BOILER 1 HEATER CONTACTOR
C3	BOILER 2 HEATER CONTACTOR
C3A	BOILER 2 HEATER CONTACTOR
C5	MAIN WASH TANK HEATERS CONTACTORS
C5A	MAIN WASH TANK HEATERS CONTACTORS
C6	2 DRYING PUMP CONTACTOR (OPTIONAL)
C7	SLOW SPEED MOTOR CONTACTOR
C9	FAST SPEED CONTACTOR
C10	OPERATION CONTACTOR (READY FOR WORKING)
C11	OPERATION CONTACTOR (RINSING BLOCK)
C12	MAIN WASHING PUMP CONTACTOR
C13	DRYING OPERATION CONTACTOR
C14	DRYING MOTORS CONTACTOR
C15	DRYING HEATERS CONTACTOR
C16	PREWASHING PUMP CONTACTOR
C21	2 DRYING HEAT CONTACTOR (OPTIONAL)
C23	ECO-RINSE PUMP CONTACTOR
C24	ECO-RINSE TANK HEATER CONTACTOR
C40	EMERGENCY SWITCH CONTACTOR
R1	DETERGENT DISPENSER RELAY
R2	RINSE AID DISPENSER RELAY
R3	NERNESS RINSING SOUNDER
R4	NERNESS SOUNDER RELAY
R6	STOP MACHINE TIMER
R7	STOP RINSE TIMER
R8	HEAT PUMP ELECTROVALVE RELAY
R9	RINSE ELECTROVALVE RELAY
R11	AUXILIARY RELAY TIMERS
R12	HEAT PUMP RELAY
PE	EMERGENCY PUSH BUTTON
PR	REARMAMENT PUSH BUTTON
S2	PRERINSING ELECTROVALVE
S3	FILLING VALVE
S5	DIFFERENTIAL PRESSURE ELECTROVALVE
S6	HEAT PUMP ELECTROVALVE
S7	RINSE ELECTROVALVE
B1	ON/OFF PUSH BUTTON
B2	PUSH BUTTON SPEED 1
B3	LIMIT SWITCH
B4	STOP PUSH BUTTON
B5	PUSH BUTTON SPEED 2
E2	DOUBLE PRESSURE SWITCH (WASHING TANK)
E4	PRESSURE SWITCH (PREWASHING TANK)
E5	WASHING TANK THERMOSTAT
E6	BOILER 1 THERMOSTAT
E6S	SAFETY THERMOSTAT BOILER 1
E7	BOILER 2 THERMOSTAT
E7S	SAFETY THERMOSTAT BOILER 2
E20	SAFETY THERMOSTAT DRYING ZONE
E21	DRYING HEATERS THERMOSTAT C15
E22	ECO RINSE THERMOSTAT
E23	PRESSURE SWITCH (ECO RINSE)
E24	HEAT DRYING THERMOSTAT C21
E25	DIFERENTIAL PRESSURE SWITCH
K	HEAT PUMP CONTACTOR
K1	HEAT PUMP TIMER
PA	HIGH PRESSURE SWITCH
PB	LOW PRESSURE SWITCH
TKG	HEAT PUMP THERMIC
MVI	FAN MOTOR RELAY HEAT PUMP
F1	ANTIPARASITIC FILTER
F2	OPERATION CONDENSER
D1	DETERGENT DISPENSER
D2	RINSE DISPENSER
M1	DOOR MICRO SWITCH CONTACTOR
M2	ON/OFF CONTACTOR
MP	DOOR MICRO SWITCH
PEM	EMERGENCY SWITCH PUSH