

Technical Sheet

Jemi Simply built to last

Professional Dishwashing and Cooking Equipment

Cookers 750 EV Series Cookers with water chamber CHEF

Selva de Mar, 122-128
08020 Barcelona, España
Tel. 0034 93 308 31 54
Fax. 0034 93 303 38 73
jemi@jemi.es
www.iemi.es

Mod. T721 CHEF EV

Characteristics

Externals dimensions 400 x 750 x 850 mm.

Weight 72 Kg.

Gas consumption Hi (15°C 1013,25 mbar)

Natural gas H G20 Hi = 34.02 MJ / m³ 1,23

G.P.L. G30 / G31 Hi = 45.65MJ / kg 0,96

Burners 2 out of ø 120 mm.

Burner power ø 120 mm. 7,4 Kw. / 6.300 Kcal/h.

Gas inlet 3/4"

Water inlet 1/2"

Drain 1"

Nominal power 14.8 Kw.

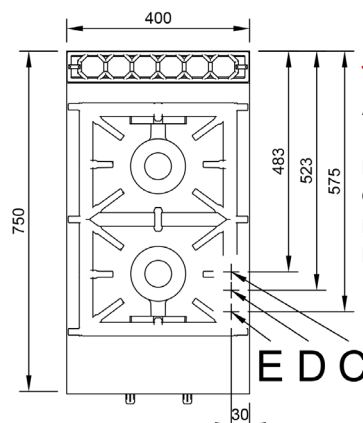
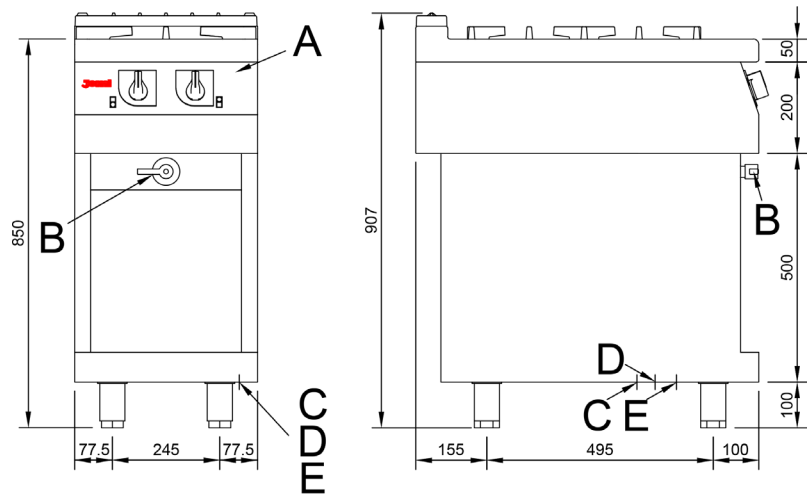

Index

- A. Characteristics plate (inside panel)
 - B. Filling tap
 - C. Water inlet 1/2"
 - D. Drain 1"
 - E. Gas inlet 3/4".
- Power: 14,8 Kw.
12.600 Kcal/h.

