

Technical Sheet

Cookers 750 EV Series Gas Fryers

Selva de Mar, 122-128
08020 Barcelona, España
Tel. 0034 93 308 31 54
Fax. 0034 93 303 38 73
jemi@jemi.es
www.iemi.es

Mod. FRG70/2 EV

Characteristics

Externals dimensions 800 x 750 x 850 mm.

Weight 98 Kg.

Gas consumption Hi (15°C 1013,25 mbar)

Natural gas H G20 Hi = 34.02 MJ / m³ 2,50

G.P.L. G30 / G31 Hi = 45.65MJ / kg 1,78

Tank dimensions W x D x H 305 x 345 x 340 mm.

Tank capacity 15 + 15 litres.

Number of baskets 4 singles or 2 doubles

Dimensions basket single W x D x H 135 x 280 x 95 mm.

Dimensions basket double W x D x H 280 x 280 x 95 mm.

Number of burners 2 + 2

Electric inlet 230V. II

Gas inlet 3/4"

Nominal power 23,80 Kw.

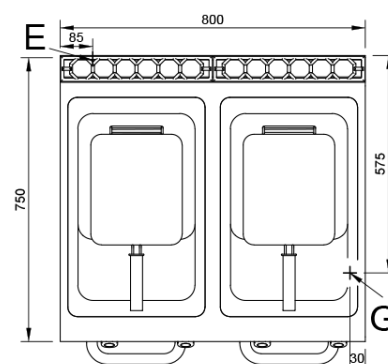
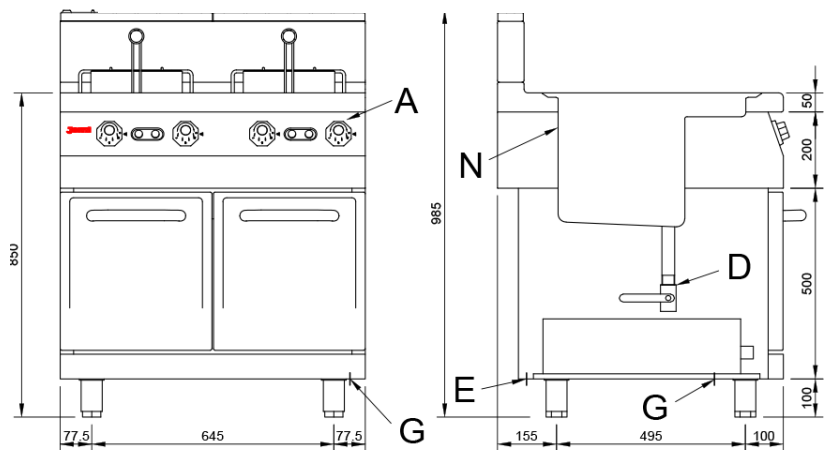

Index

A. Characteristics plate
(inside panel)

D. Drain.

E Electric inlet 230V. II.

G. Gas inlet 3/4".

N. Level

Power: 23,80 Kw.

20.468 Kcal/h.

