

Technical Sheet

Cookers 900 EV Series Electric Fry-Top Quick griddles

Jemi Simply built to last

Professional Dishwashing
and Cooking Equipment

Selva de Mar, 122-128
08020 Barcelona, España
Tel. 0034 93 308 31 54
Fax. 0034 93 303 38 73
jemi@jemi.es
www.jemi.es

Mod. FRTE90 / P94VT EV

Characteristics

External dimensions 800 x 900 x 850 mm.

Weight 163 Kg.

Voltage 400V. III + N + T

Useful area 741 x 656 mm.

Type surface 1/2 Grooved (CHROME PLATE)

Nominal power 15 Kw.

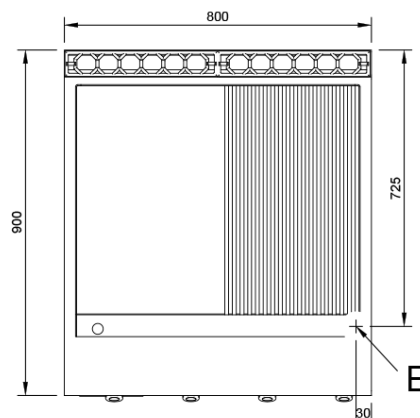
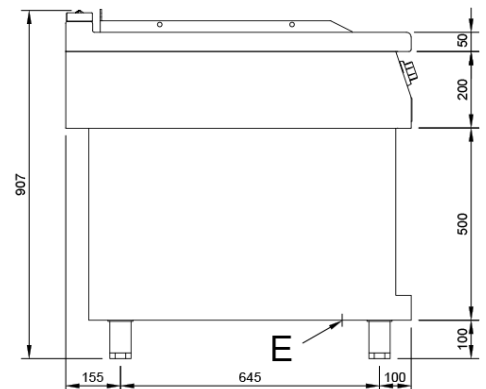
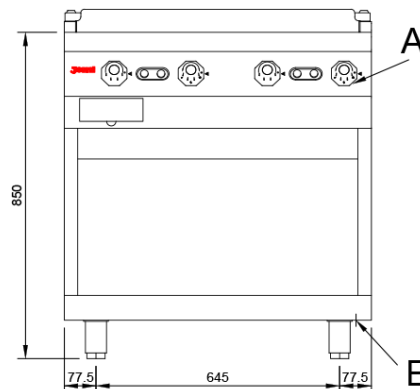

Index

- A. Characteristics plate
(inside panel)
- G. Electric inlet 400V III + N + T.
Power: 15 Kw.

