

Technical Sheet

Jemi Simply built to last

Professional Dishwashing and Cooking Equipment

Selva de Mar, 122-128
08020 Barcelona, España
Tel. 0034 93 308 31 54
Fax. 0034 93 303 38 73
jemi@jemi.es

Cookers 750 Series EV Gas Boiling Pans

Mod. MAG50I EV

Characteristics

Nominal power 10 Kw.

Gas consumption Hi (15°C 1013,25 mbar)

Natural gas H G20 Hi = 34.02 MJ / m³ 0,84

G.P.L. G30 / G31 Hi = 45.65 MJ / kg 0,78

Tank capacity 50 litres

Tank dimensions \varnothing 395 x 440 mm.

Type of heat Indirect heat

Gas inlet 1/2"

External dimensions 800 x 750 x 850 mm.

Weight 119 Kg.

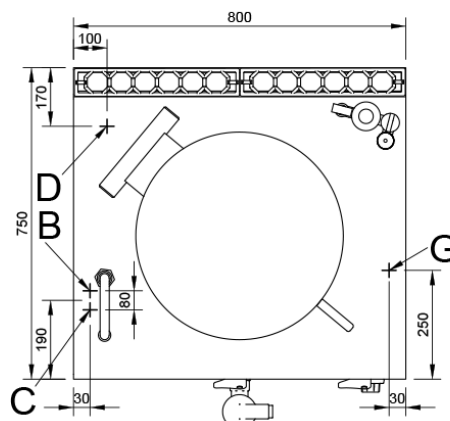
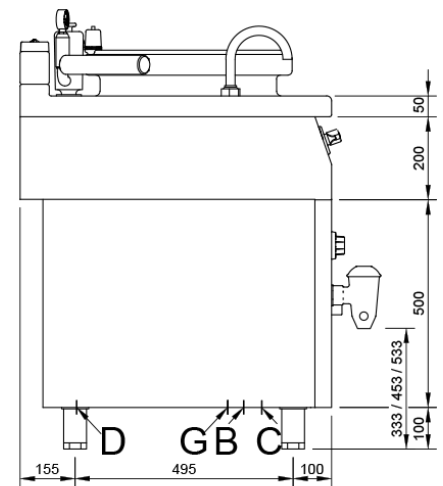
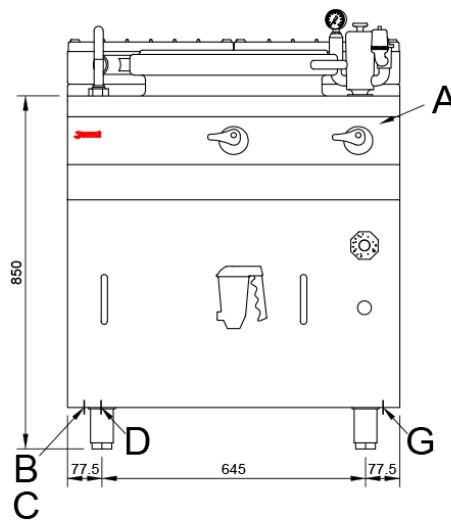

Index

- A. Characteristics plate (Inside panel)
 - B. Hot water inlet (1/2").
 - C. Cold water inlet (1/2").
 - D. Overflow drain.
 - G. Gas inlet 1/2"
- Power: 10 Kw.
Kcal./h. 8.600

